

IMPORTANT: Before Installing

Please take the time to read through the ENTIRE instructions prior to starting any work.

Precautions

1. Light Pipe material is very sharp when cut. Please use extreme caution when handling the light pipe.
2. Light Pipe is very bright, use proper eye protection when installing. **AVOID LEAVING THE PIPE EXPOSED TO THE SUN WITHOUT THE PROTECTIVE COATING OR DIFFUSERS IN PLACE PRIOR TO INSTALLATION.** (The protective coating should only be removed during Step 14.)
3. Ensure normal safety precautions are taken when using tools and walking on roofs.
4. Do not cut any structural members in the house.
5. Ensure wire runs, plumbing or ventilation ducts will not interfere with the light pipe installation.
6. Measure twice and cut once.

Parts List

1. Clear UV Protected, High Impact Acrylic Dome
2. (4) Phillips Head Stainless Steel 1/4" Sheet Metal Screws
3. Black Nylon Horse Hair Gasket (self adhesive backed)
4. (6) Philip Head Stainless Steel 1 1/2" Screws
5. 1100 Series Aluminum Flashing
6. Heavy Duty Foil Tape
7. Light Pipe
8. White Nylon Horse Hair Gasket (self adhesive backed)
9. (8) Tek Screws
10. (3) Black Speed Nuts
11. Ceiling Ring
12. (3) 1 1/2" Phillips Screws
13. White Powder Coated Aluminum Trim Ring
14. High Impact Acrylic Soft White or Prismatic Diffuser

Optional: (not included)

Angle Adapter

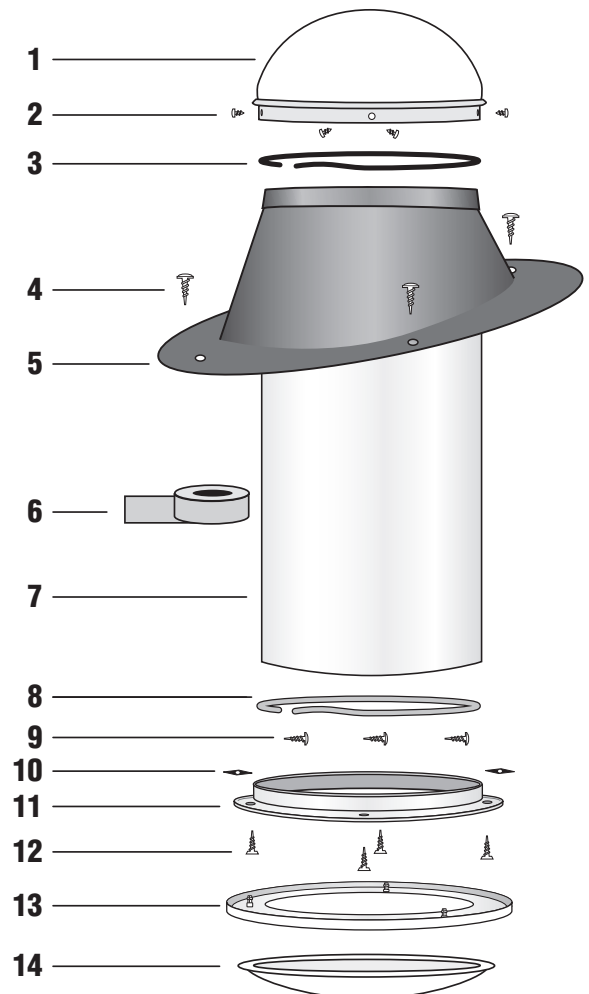
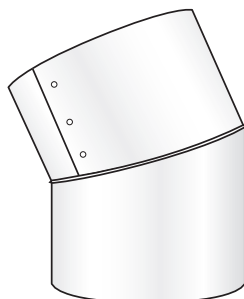

Tools Required

- Reciprocating Saw
- Measuring Tape
- Hammer
- Drill & Bits
- Drywall Saw
- Razor Knife
- Flat Bar
- Flashlight
- Caulking Gun
- Stud Finder
- Drop Cloth
- Ladders
- Marking Pen
- Wire
- Tin Snips

Installation Pointers

- When determining location of the unit, try to place the flashing unit on the south side of the roof, also consider potential problems such as objects shading the unit during certain times of the day.
- Although adjustable elbows are available for use, straight light pipe runs result in higher light output and easier installation.
- Prior to starting the job, clean off the oil residue on the flashing.
- It is highly critical to check for obstructions above the ceiling which may hinder the installation. If possible, visually check to ensure that there are no electrical wires or other obstructions where you plan to install the skylight. If you can not check visually, use a piece of wire as outlined in Step 1.

Step 1

To facilitate installation, once the desired location is obtained, ensure that there are no obstructions in the attic between the roof and ceiling. With a stud finder locate the ceiling joists and center ceiling ring between joists as close to the desired installation area as possible. Mark the center of the ceiling ring, drill a hole and insert piece of wire bent at a 90 degree angle. Rotate the wire around 360 degrees. While rotating, feel for resistance that could indicate wire runs or other obstructions.

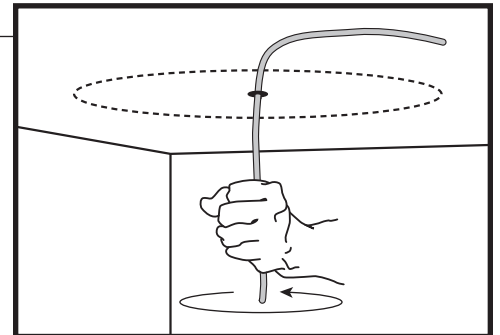

Step 2

If there are no obstructions, scribe a mark around the ceiling ring inner collar, **see diagram**. Using a drywall saw, cut out the scribed mark in the ceiling.

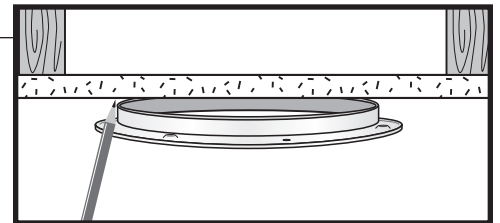

Step 3

Install the ceiling ring in the ceiling. Place ceiling ring in the ceiling. Peel the protective covering off the white colored horse hair gasket and apply gasket to the inner lip of the ceiling ring. This gasket ensures a dust free fit between the light pipe and the ceiling ring. Secure the ceiling ring to ceiling by inserting a white screw into one of the three pre-drilled holes and screwing it up through the drywall into speed nut provided. Repeat this process for all three screws.

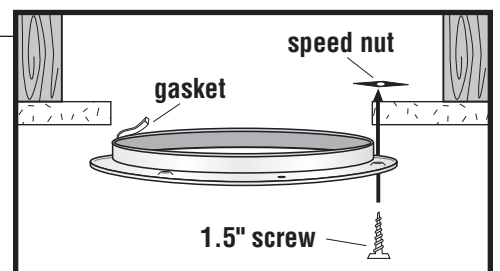

Step 4

For the roof penetration, place a step ladder under the ceiling ring hole and place a flashlight on top of the ladder, the resulting flashlight beam will mark the location for the centering hole of the flashing unit on the roof. With a drill bit and appropriate extension rods, drill a pilot hole in the marked location on the bottom side of the roof.

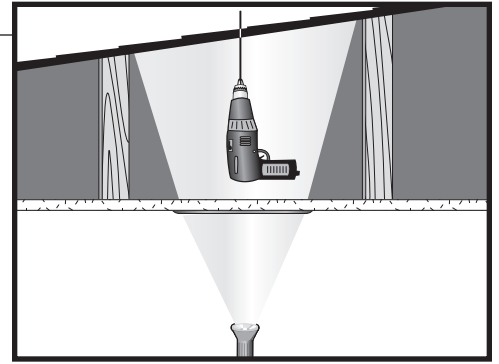

Step 5

On the roof, locate the centering hole and outline the diameter of the hole that the pipe will pass through by turning the flashing upside down and marking the inside lip of the flashing unit (see diagram).

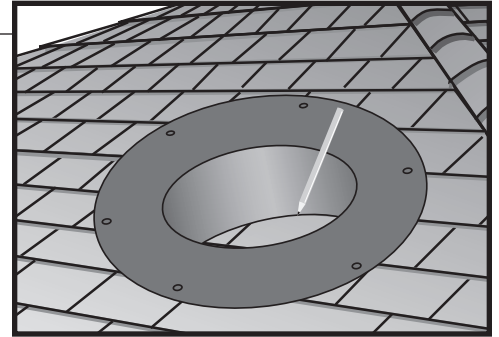

Step 6

IMPORTANT: The light pipe must pass between the roof rafters. **DO NOT CUT THROUGH ANY FRAMING MEMBER.**

With a reciprocating saw, cut the diameter of the hole 1" larger than the area marked in Step 5.

NOTE: On skewed skylight installations, a larger hole may be necessary to accommodate the angle of the light pipe.

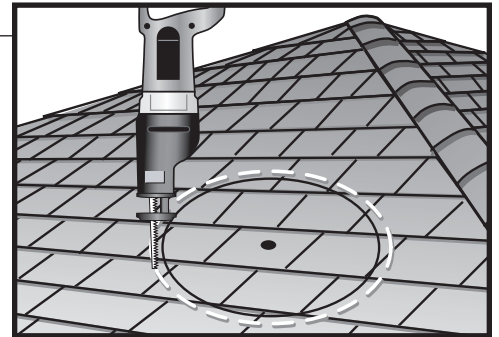

Step 7 (skip this step for flat roof applications and proceed to Step 9)

With a razor knife, cut a four inch slit through the shingles and tar paper at the three and nine o'clock position of the flashing. This allows for the foot print of the flashing to be inserted under the shingles.

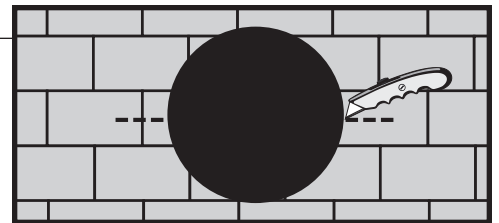

Step 8 (skip this step for flat roof applications and proceed to Step 9)

Insert the reciprocating saw blade sideways at the three o'clock position and commence cutting the roofing nails up and around to the nine o'clock position. This process removes the nails that will prevent the flashing foot print from sliding up underneath the shingles.

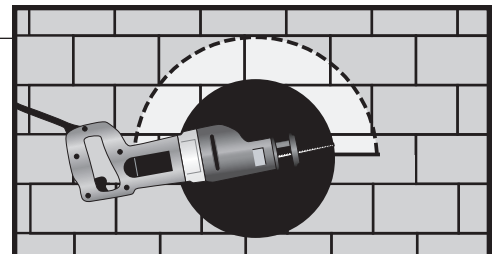

Step 9

Caulk **underside** of flashing with the provided caulking material. Two concentric rings of caulking material is sufficient.

NOTE: Installation on tile roofs will require the use of a skirt.

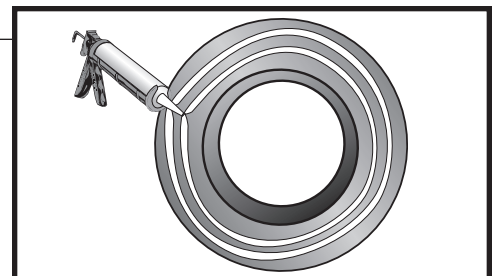

Step 10

Pitched Roofs: Taking care not to smear caulk on the exposed shingles, slide flashing under tar paper and shingles and force flashing up until the shingles come in contact with the raised portion of the flashing. The bottom side of the flashing will be on top of the shingles. Secure flashing with six Phillips head screws at the 2:00, 4:00, 6:00, 8:00, 10:00 and 12:00 positions. The 10:00, 12:00 and 2:00 positions screws should go under the shingles. The 4:00, 6:00 and 8:00 position screws should go on top of the shingles.

Flat Roofs: Center flashing over the hole cut in Step 6 and attach to roof with the Phillips screws provided through the pre-drilled holes.

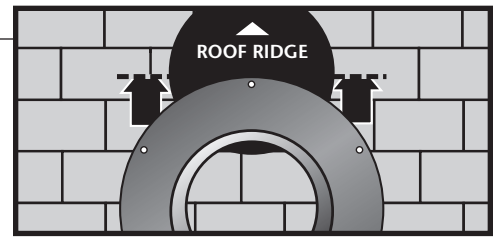

PITCHED ROOF

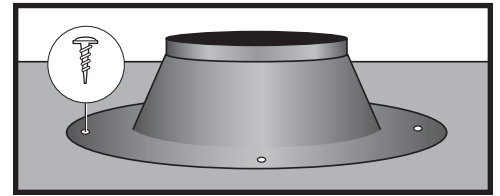

FLAT ROOF

Step 11

Pitched Roofs: At the 4:00, 6:00 and 8:00 positions, caulk over the screw head, since it will be exposed to the weather. Use remaining caulk to seal the areas where the 4" slits were made and around the area where the shingles meet with the raised area of the flashing.

Flat Roofs: Caulk over all the screw heads since they will be exposed to the weather.

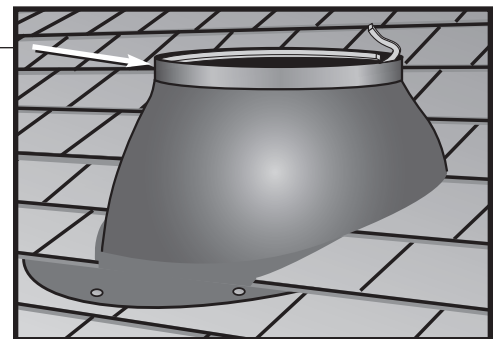
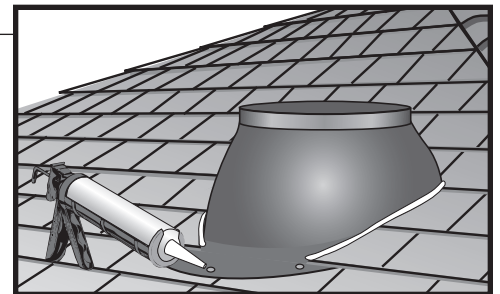

Step 12

Peel the protective backing off the black horse hair gasket and apply gasket on the inner lip of the flashing collar.

Step 13

To assemble light pipe, peel back the protective coating that covers the mirror coating about 1" from the opposite edge of the double sided tape, remove paper cover over double sided tape and overlap and seal edges. Put pressure on both sides of seal to ensure a good bond. Secure tube using the (2) tek screws provided. Then place foil tape over the entire seam to strengthen seal.

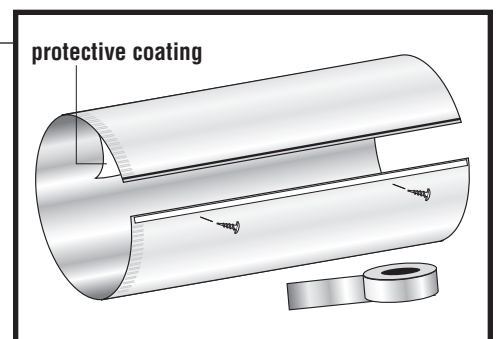

Step 14

When joining two pipe sections together, with the crimped end down, place crimped end into the next section of pipe. Secure with a tek screws and seal joints with foil tape.

IMPORTANT: Remove protective coating that covers the mirror finish inside the tube.



Step 15

Insert pipe through the flashing unit and gently rock pipe back and forth with slight downward pressure until pipe terminates evenly with the inner collar of the ceiling ring. Secure bottom of light pipe to ceiling ring with two tek screws.

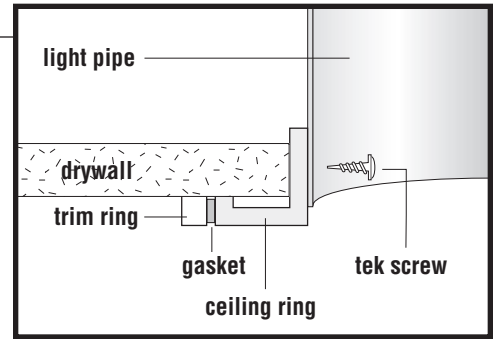

Step 16

If there is excess pipe sticking out of the flashing, using tin snips, cut from the top down to the lip of the flashing and trim off the excess pipe.

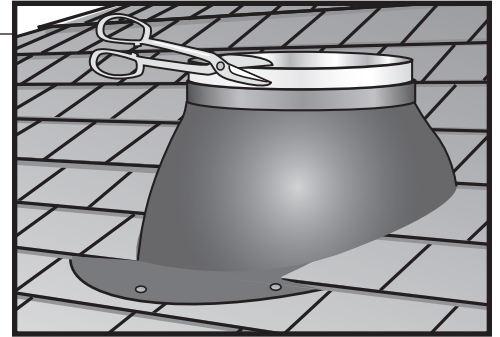

Step 17

Place dome on top of the flashing unit. Secure dome to flashing by screwing in four screws into the pre-drilled holes in the dome collar.

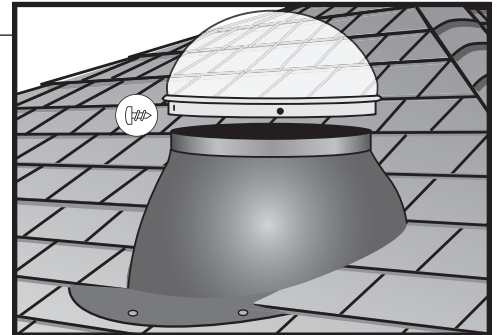

Step 18

Place the diffuser into the white powder coated trim ring.

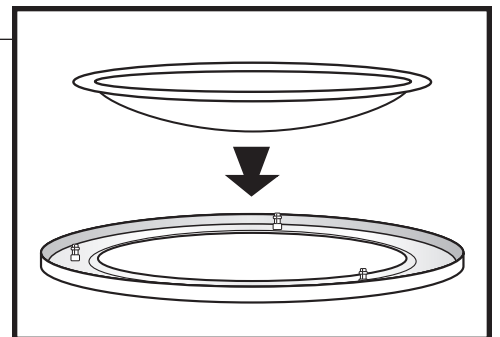

Step 19

Line up the 3 steel pins of the white powder coated trim ring with the 3 holes on the ceiling ring. Push up to snap in place.

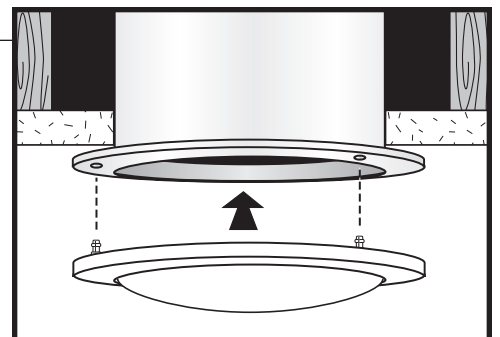

Natural Light
Tubular Skylights

W A R R A N T Y

This Natural Light Tubular Skylight has a 25 year warranty against manufacturers defects and deterioration.

IMPORTANT: PLEASE COMPLETE AND MAIL THE CARD BELOW AS SOON AS YOUR TUBULAR SKYLIGHT IS INSTALLED. This card will serve as proof of your purchase, should you misplace your original invoice.

The manufacturer warrants this product and its components to be free from defects in material and manufacturer's workmanship for a period of twenty five years from the date of installation. This warranty is subject to proper installation of the unit in accordance with the manufacturer's written installation instructions. The manufacturer will not be liable for any special, incidental or consequential damages in any way related to, or arising out of, defects in, or damage to, the tubular skylight.

This warranty gives you specific legal rights, and you may have other rights which vary from state to state concerning exclusion or limitation of incidental or consequential damages.

Please fill out the form below and mail it to:

Natural Light Energy Systems • 10821 North 23rd Avenue • Phoenix, AZ 85029

REGISTRATION

Natural Light Tubular Skylight Installer: _____

Date of Purchase: _____

Customer Name: _____

Address: _____

City: _____ State: _____ Zip: _____

Customer Survey

Are you satisfied with the performance? Y N

What made you choose our product?

Were you satisfied with the installation job?